



# High Force Air Nozzles



Some applications require extremely high force with extensive reach. EXAIR offers most standard nozzles in a high force version. With incredibly high blowing forces these nozzles are ideal for part ejection as well as blowoff, cooling and drying applications. EXAIR has engineered Large Super Air Nozzles that put the blowing capability of multiple nozzles into one single air nozzle. Hard-hitting force is measured in pounds, not ounces. All meet OSHA noise level and dead end pressure requirements.

## High Force Air Nozzles "Quick Pick" Comparison

High Force Air Nozzles Comparison (sorted by compressed air consumption)

Model	Material	Description	Inlet	Air Consumption at 80 PSIG (5.5 BAR)		Force		Sound Level dBA	More Details
				SCFM	SLPM	Lbs	Grams		
HP1126	Zinc Aluminum alloy	1" High Power Flat Super Air Nozzle	1/8 FNPT	17.5	495	1 <sup>†</sup>	454	82	p. 63
HP1126SS	Stainless Steel - Type 316	1" High Power Flat Super Air Nozzle	1/8 FNPT	17.5	495	1 <sup>†</sup>	454	82	p. 63
HP1002	Brass	High Power Safety Air Nozzle	1/4 FNPT	32	906	1.8*	816	87	p. 64
HP1002SS	Stainless Steel - Type 303	High Power Safety Air Nozzle	1/4 FNPT	32	906	1.8*	816	87	p. 64
1104	Zinc Aluminum alloy	Super Air Nozzle	3/8 FNPT	35	991	1.9*	862	82	p. 64
1104SS	Stainless Steel - Type 316	Super Air Nozzle	3/8 FNPT	35	991	1.9*	862	82	p. 64
1104-PEEK	PEEK (Plastic)	Super Air Nozzle	3/8 FNPT	35	991	1.9*	862	82	p. 64
1105	Zinc Aluminum alloy	Super Air Nozzle	3/8 MNPT	35	991	1.9*	862	82	p. 64
1105SS	Stainless Steel - Type 316	Super Air Nozzle	3/8 MNPT	35	991	1.9*	862	82	p. 64
HP1125	Zinc Aluminum alloy	2" High Power Flat Super Air Nozzle	1/4 FNPT	37	1,039	2.2 <sup>†</sup>	998	83	p. 64
HP1125SS	Stainless Steel - Type 316	2" High Power Flat Super Air Nozzle	1/4 FNPT	37	1,039	2.2 <sup>†</sup>	998	83	p. 64
1111-4	Zinc Aluminum alloy	Super Air Nozzle Cluster	3/8 FNPT	56	1,585	3.2*	1,451	82	p. 67
1008SS	Stainless Steel - Type 316	Back Blow Air Nozzle	1 FNPT	57	1,614	NA	NA	89	p. 59
1106	Zinc Aluminum alloy	Super Air Nozzle	1/2 FNPT	60	1,699	3.3*	1,497	87	p. 65
1106SS	Stainless Steel - Type 316	Super Air Nozzle	1/2 FNPT	60	1,699	3.3*	1,497	87	p. 65
1107	Zinc Aluminum alloy	Super Air Nozzle	1/2 MNPT	60	1,699	3.3*	1,497	87	p. 65
1107SS	Stainless Steel - Type 316	Super Air Nozzle	1/2 MNPT	60	1,699	3.3*	1,497	87	p. 65
1112	Zinc Aluminum alloy	Super Air Nozzle	3/4 FNPT	91	2,577	4.5*	2,041	96	p. 65
1112SS	Stainless Steel - Type 316	Super Air Nozzle	3/4 FNPT	91	2,577	4.5*	2,041	96	p. 65
1113	Zinc Aluminum alloy	Super Air Nozzle	3/4 MNPT	91	2,577	4.5*	2,041	96	p. 65
1113SS	Stainless Steel - Type 316	Super Air Nozzle	3/4 MNPT	91	2,577	4.5*	2,041	96	p. 65
1111-7	Zinc Aluminum alloy	Super Air Nozzle Cluster	1/2 FNPT	98	2,773	5.7*	2,585	85	p. 67
1114	Zinc Aluminum alloy	Super Air Nozzle	1 FNPT	135	3,823	6.6*	2,994	99	p. 65
1114SS	Stainless Steel - Type 316	Super Air Nozzle	1 FNPT	135	3,823	6.6*	2,994	99	p. 65
1115	Zinc Aluminum alloy	Super Air Nozzle	1 MNPT	135	3,823	6.6*	2,994	99	p. 65
1115SS	Stainless Steel - Type 316	Super Air Nozzle	1 MNPT	135	3,823	6.6*	2,994	99	p. 65
1111-12	Zinc Aluminum alloy	Super Air Nozzle Cluster	1 FNPT	168	4,754	9.8*	4,445	89	p. 67
1116	Zinc Aluminum alloy	Super Air Nozzle	1-1/4 FNPT	188	5,324	9.4*	4,264	102	p. 66
1117	Zinc Aluminum alloy	Super Air Nozzle	1-1/4 MNPT	188	5,324	9.4*	4,264	102	p. 66
1118	Zinc Aluminum alloy	Super Air Nozzle	1-1/4 FNPT	300	8,495	15*	6,804	106	p. 66
1119	Zinc Aluminum alloy	Super Air Nozzle	1-1/4 MNPT	300	8,495	15*	6,804	106	p. 66
1120	Zinc Aluminum alloy	Super Air Nozzle	1-1/4 FNPT	460	13,026	23*	10,433	109	p. 66
1121	Zinc Aluminum alloy	Super Air Nozzle	1-1/4 MNPT	460	13,026	23*	10,433	109	p. 66

Air Nozzles & Jets

For Air Nozzles with lower force, see page 54.

\* Force measured at 12" (305mm) from target. All sound levels measured at 3 feet (914mm). All measurements taken at 80 PSIG (5.5 BAR)

† Force measured at 12" (305mm) from target with a .025" (0.64mm) shim installed.

FNPT = NPT Female, MNPT = NPT Male

### 1" High Power Flat Super Air Nozzles™



**Model HP1126** 1/8 NPT female  
**Material:** Zinc Aluminum alloy

**Model HP1126SS** 1/8 NPT female  
**Material:** Type 316 Stainless Steel



A 1" High Power Flat Super Air Nozzle is used to tip a part from a chute and on to a conveyor.

#### Model HP1126 and HP1126SS 1" High Power Flat Super Air Nozzles

EXAIR's 1" High Power Flat Super Air Nozzles produce a flat 1" (25mm) wide airstream with a blowing force of 1 pound. The unique design of this super-efficient nozzle makes it an ideal fit for both tight spaces and tight budgets. It uses EXAIR's patented technology to maximize entrained airflow while reducing noise levels.

Air Consumption		Force*		Sound Level
SCFM	SLPM	Lbs	Grams	dBa
17.5	495	1	454	82

\* Force measured at 12" (305mm) from target. Sound level measured at 3' (914mm). All measurements taken at 80 PSIG (5.5 BAR). .025" (0.64mm) shim installed.

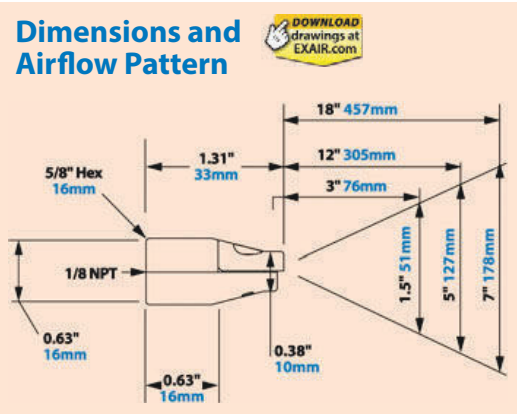

The Model HP1136SS Shim Set for the 1" High Power Flat Super Air Nozzle includes a .020" (0.51mm) and .030" (0.76mm) thick shim. A .025" (0.64mm) shim is installed.



# High Force Air Nozzles

## High Power Safety Air Nozzles™



**Model HP1002** 1/4 NPT female  
**Material:** Brass

**Model HP1002SS** 1/4 NPT female  
**Material:** Type 303 Stainless Steel

### Model HP1002 and HP1002SS High Power Safety Air Nozzles

Provide strong blowing force for applications requiring high thrust and velocity. It uses more compressed air than other air nozzles but is low when compared to typical blowoffs delivering the same force.

Air Consumption		Force*		Sound Level
SCFM	SLPM	Lbs	Grams	dBA
32	906	1.8	816	87

\* Force measured at 12" (305mm) from target  
Sound level measured at 3' (914mm)  
All measurements taken at 80 PSIG (5.5 BAR)

### Dimensions and Airflow Pattern

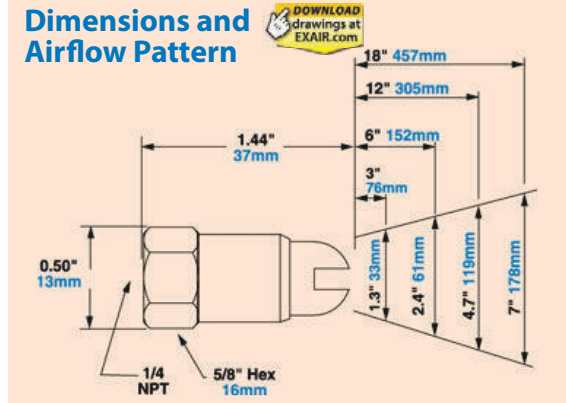

DOWNLOAD drawings at EXAIR.com

Air Nozzles & Jets

## 2" High Power Flat Super Air Nozzles™



**Model HP1125** 1/4 NPT female  
**Material:** Zinc Aluminum alloy

**Model HP1125SS** 1/4 NPT female  
**Material:** Type 316 Stainless Steel

### Model HP1125 and HP1125SS 2" High Power Flat Super Air Nozzles

EXAIR's 2" High Power Flat Super Air Nozzles produce a flat 2" (51mm) wide airstream with a strong blowing force of 2.2 pounds (998 grams). The adjustable force is more than three times that of ordinary air nozzles. It uses EXAIR's patented† technology to maximize entrained airflow while reducing noise levels.

Air Consumption		Force*		Sound Level
SCFM	SLPM	Lbs	Grams	dBA
37	1,039	2.2	998	83

\* Force measured at 12" (305mm) from target.  
Sound level measured at 3' (914mm).  
All measurements taken at 80 PSIG (5.5 BAR).  
.025" (0.64mm) shim installed.

† Patent #5402938

### Dimensions and Airflow Pattern

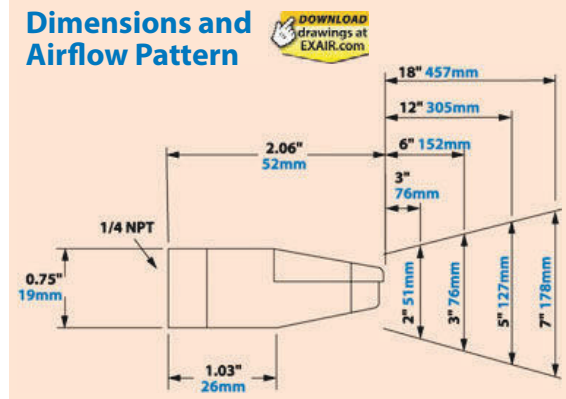

DOWNLOAD drawings at EXAIR.com



Note: For highest force and flow, order Model 900633 .030" (0.76mm) shim.

The Model HP1132SS Shim Set for the 2" High Power Flat Super Air Nozzle includes a .020" (0.51mm) and .030" (0.76mm) thick shim. A .025" (0.64mm) shim is installed.

## Large Super Air Nozzles™



**Model 1104** 3/8 NPT female  
**Material:** Zinc Aluminum alloy

**Model 1104SS** 3/8 NPT female  
**Material:** Type 316 Stainless Steel

**Model 1104-PEEK** 3/8 NPT female  
**Material:** PEEK (plastic)



**Model 1105** 3/8 NPT male  
**Material:** Zinc Aluminum alloy

**Model 1105SS** 3/8 NPT male  
**Material:** Type 316 Stainless Steel

### Model 1104, 1104SS, 1104-PEEK, 1105 and 1105SS 3/8 NPT Super Air Nozzles

EXAIR's 3/8 NPT Super Air Nozzles produce 1.9 lbs (862 grams) of strong blowing force that is 2.3 times that of the standard Super Air Nozzle. The protective aerodynamic slots guide the airflow to a single point of convergence for hard-hitting force and dramatic noise reduction over typical blowoffs.

Air Consumption		Force*		Sound Level
SCFM	SLPM	Lbs	Grams	dBA
35	991	1.9	862	82

\* Force measured at 12" (305mm) from target  
Sound level measured at 3' (914mm)  
All measurements taken at 80 PSIG (5.5 BAR)

### Dimensions and Airflow Pattern

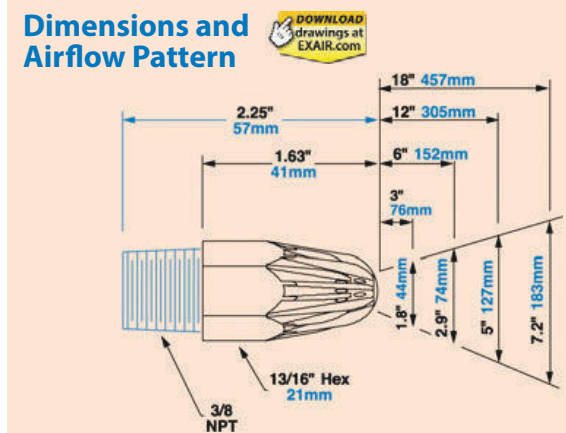

DOWNLOAD drawings at EXAIR.com



## Large Super Air Nozzles™



**Model 1106** 1/2 NPT female  
**Material:** Zinc Aluminum alloy

**Model 1106SS** 1/2 NPT female  
**Material:** Type 316 Stainless Steel



**Model 1107** 1/2 NPT male  
**Material:** Zinc Aluminum alloy

**Model 1107SS** 1/2 NPT male  
**Material:** Type 316 Stainless Steel

### Model 1106, 1106SS, 1107 and 1107SS 1/2 NPT Super Air Nozzles

EXAIR's 1/2 NPT Super Air Nozzles produce 3.3 lbs (1.5 kg) of blowing force – 4 times that of ordinary nozzles. Air consumption and noise are extremely low compared to that of open pipe or copper tubes.

Air Consumption		Force*		Sound Level
SCFM	SLPM	Lbs	Kg	dBA
60	1,699	3.3	1.5	87

\* Force measured at 12" (305mm) from target  
Sound level measured at 3' (914mm)  
All measurements taken at 80 PSIG (5.5 BAR)



### Dimensions and Airflow Pattern

DOWNLOAD drawings at EXAIR.com

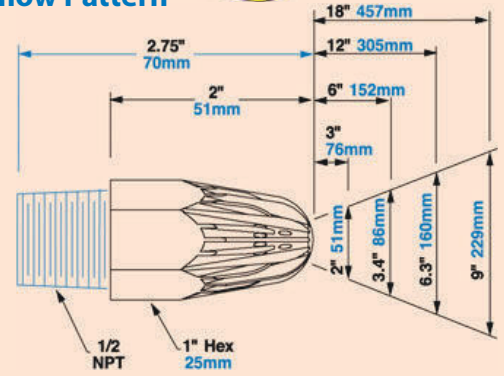

Air Nozzles & Jets



**Model 1112** 3/4 NPT female  
**Material:** Zinc Aluminum alloy

**Model 1112SS** 3/4 NPT female  
**Material:** Type 316 Stainless Steel



**Model 1113** 3/4 NPT male  
**Material:** Zinc Aluminum alloy

**Model 1113SS** 3/4 NPT male  
**Material:** Type 316 Stainless Steel

### Model 1112, 1112SS, 1113 and 1113SS 3/4 NPT Super Air Nozzles

EXAIR's Super Air Nozzles are available in larger sizes where extreme force is required. The 3/4 NPT Super Air Nozzles produce 4.5 lbs (2.04 kg) of blowing force – over 5 times that of ordinary nozzles.

Air Consumption		Force*		Sound Level
SCFM	SLPM	Lbs	Kg	dBA
91	2,577	4.5	2.04	96

\* Force measured at 12" (305mm) from target  
Sound level measured at 3' (914mm)  
All measurements taken at 80 PSIG (5.5 BAR)  
OSHA allows 3 hours of exposure per day without hearing protection.

### Dimensions and Airflow Pattern

DOWNLOAD drawings at EXAIR.com

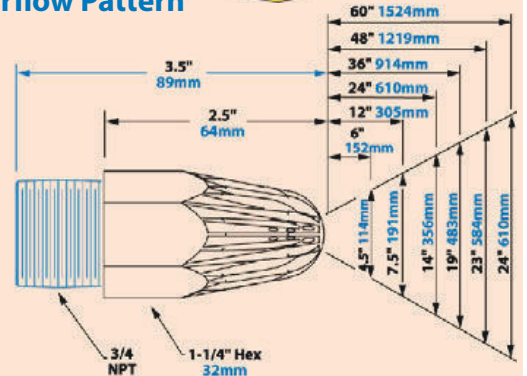

**Model 1114** 1 NPT female  
**Material:** Zinc Aluminum alloy

**Model 1114SS** 1 NPT female  
**Material:** Type 316 Stainless Steel



**Model 1115** 1 NPT male  
**Material:** Zinc Aluminum alloy

**Model 1115SS** 1 NPT male  
**Material:** Type 316 Stainless Steel

### Model 1114, 1114SS, 1115 and 1115SS 1 NPT Super Air Nozzles

EXAIR's 1 NPT Super Air Nozzles optimize entrained airflow across the nozzle surface to minimize the noise level while providing extremely strong blowing force. They produce 6.6 lbs (3.01 kg) of blowing force – over 8 times that of ordinary nozzles.

Air Consumption		Force*		Sound Level
SCFM	SLPM	Lbs	Kg	dBA
135	3,823	6.6	2.99	99

\* Force measured at 12" (305mm) from target  
Sound level measured at 3' (914mm)  
All measurements taken at 80 PSIG (5.5 BAR)  
OSHA allows 2 hours of exposure per day without hearing protection.



### Dimensions and Airflow Pattern

DOWNLOAD drawings at EXAIR.com

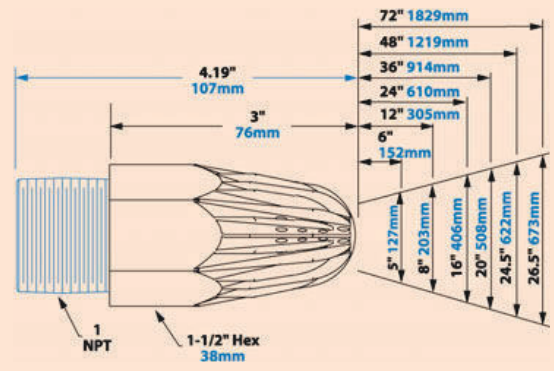





# High Force Air Nozzles

## Large Super Air Nozzles™

### Model 1116 and 1117 1-1/4 NPT Super Air Nozzles

EXAIR's 1-1/4 NPT Super Air Nozzles provide exceptionally strong blowing force. They produce 9.4 lbs (4.25 kg) of blowing force – almost 12 times that of the standard Super Air Nozzle.

Air Consumption		Force*		Sound Level
SCFM	SLPM	Lbs	Kg	dBA
188	5,324	9.4	4.26	102

\* Force measured at 12" (305mm) from target  
Sound level measured at 3' (914mm)  
All measurements taken at 80 PSIG (5.5 BAR)  
OSHA allows 1 hour of exposure per day  
without hearing protection.



### Dimensions and Airflow Pattern

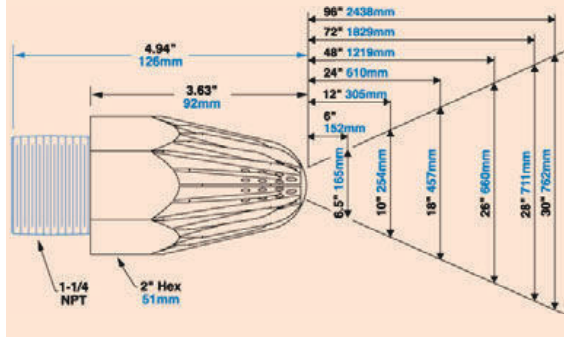

**Model 1116** 1-1/4 NPT female  
**Material:** Zinc Aluminum alloy



**Model 1117** 1-1/4 NPT male  
**Material:** Zinc Aluminum alloy

Air Nozzles & Jets

### Model 1118 and 1119 1-1/4 NPT Super Air Nozzles

These 1-1/4 NPT Super Air Nozzles have larger orifices than the Model 1116 / 1117 that provide additional air velocity. They generate 15 lbs (6.80 kg) of blowing force – almost 18 times that of the standard Super Air Nozzle.

Air Consumption		Force*		Sound Level
SCFM	SLPM	Lbs	Kg	dBA
300	8,495	15	6.80	106

\* Force measured at 12" (305mm) from target  
Sound level measured at 3' (914mm)  
All measurements taken at 80 PSIG (5.5 BAR)  
OSHA allows 1/2 hour of exposure per day  
without hearing protection.

### Dimensions and Airflow Pattern

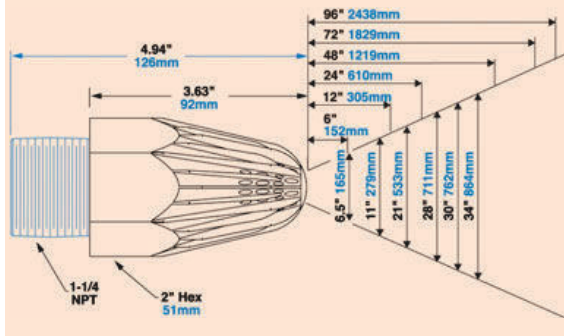

**Model 1118** 1-1/4 NPT female  
**Material:** Zinc Aluminum alloy



**Model 1119** 1-1/4 NPT male  
**Material:** Zinc Aluminum alloy

### Model 1120 and 1121 1-1/4 NPT Super Air Nozzles

These 1-1/4 NPT Super Air Nozzles have the largest orifices that provide additional air velocity, and generate the strongest blowing force of any single air nozzle. They produce 23 lbs (10.43 kg) of blowing force – almost 28 times that of the standard Super Air Nozzle.

Air Consumption		Force*		Sound Level
SCFM	SLPM	Lbs	Kg	dBA
460	13,026	23	10.43	109

\* Force measured at 12" (305mm) from target  
Sound level measured at 3' (914mm)  
All measurements taken at 80 PSIG (5.5 BAR)  
OSHA allows 1/2 hour of exposure per day  
without hearing protection.

### Dimensions and Airflow Pattern

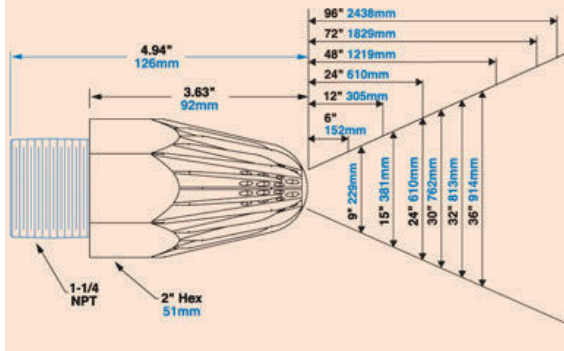

**Model 1120** 1-1/4 NPT female  
**Material:** Zinc Aluminum alloy



**Model 1121** 1-1/4 NPT male  
**Material:** Zinc Aluminum alloy